



## Calculation of shaped couplings of shafts with hubs

- i Calculation: A = OK; B = OK; C = OK; D = OK  
 ii  Project information

### 1.0 Common input data

#### A Parallel side keys

### 2.0 Coupling parameters, key material, dimensional design

2.1	Coupling parameters	
2.2	Key type	A ... ANSI B17.1
2.3	Number of keys	1
2.4	Load distribution factor	$K_L$ 1,00
2.5	Total service factor	$K_S$ 2,00 <input checked="" type="checkbox"/>

### 2.6 Key material (min. tensile strength) [hardness]

2.7	B...Carbon steel (72) [HB 220-270]	<input checked="" type="checkbox"/>
2.8	Ultimate tensile strength	$S_{Umin}$ 72 [ksi]
2.9	Permissible pressure	$p_A$ 19 [ksi]
2.10	Permitted stress in shear	$\tau_A$ 30 [ksi]

### 2.11 Design of coupling dimensions

2.12	Keys for diameters	0,3125 ~ 11	[in]
2.13	Min. shaft diameter	$d_{1min}$ 0,714	[in]
2.14	Shaft diameter	$d$ 1,375	[in]
2.15	Key	5/16 x 5/16	<input checked="" type="checkbox"/>
2.16	Key width / height	$b / h$ 0,3125   0,3125	[in]
2.17	Key radius / chamfer	$R / s$ 0,15625   0,01	[in]
2.18	Parameters of the key groove	$t / d_1$ 0,17   1,205	[in]
2.19	Min. functional key length	$L_{fmin}$ 1,242	[in]
2.20	Minimum key length	$L_{min}$ 1,555	[in]
2.21	Permitted range of key lengths	0,375 ~ 3	[in]
2.22	Chosen key length	$L$ 1,750	[in] <input checked="" type="checkbox"/>

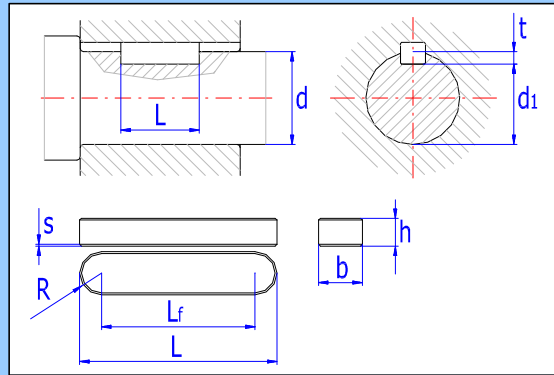

### 3.0 Strength checks of the coupling

3.1	Check of shaft for torsion	
3.2	Permitted stress in shear	$\tau_A$ 30 [ksi]
3.3	Comparative stress	$\tau$ 3,7 [ksi]
3.4	Safety	8,18
3.9	Check of key for deformation	
3.10	Permissible pressure	$p_A$ 19 [ksi]
3.11	Comparative pressure	$p$ 9,7 [ksi]
3.12	Safety	1,97

### 3.5 Check of shaft key groove for deformation

3.5	Check of shaft key groove for deformation	
3.6	Permissible pressure	$p_A$ 19 [ksi]
3.7	Comparative pressure	$p$ 9,7 [ksi]
3.8	Safety	1,97
3.13	Check of hub key groove for deformation	
3.14	Permissible pressure	$p_A$ 20 [ksi]
3.15	Comparative pressure	$p$ 7,5 [ksi]
3.16	Safety	2,67

#### B Woodruff's keys

### 4.0 Coupling parameters, key material, dimensional design

4.1	Coupling parameters	
4.2	Key type	A ... ANSI B17.2 A - Full radius type
4.3	Number of keys	1
4.4	Load distribution factor	$K_L$ 1,00
4.5	Total service factor	$K_S$ 2,00 <input checked="" type="checkbox"/>

### 4.6 Key material (min. tensile strength) [hardness]

4.7	B...Carbon steel (72) [HB 220-270]	<input checked="" type="checkbox"/>
4.8	Ultimate tensile strength	$S_{Umin}$ 72 [ksi]
4.9	Permissible pressure	$p_A$ 19 [ksi]
4.10	Permitted stress in shear	$\tau_A$ 30 [ksi]

### 4.11 Automatic design of the coupling

4.12	Assort design results according to	Shaft diameter					
4.13	Start of design						
4.14	ID.	d	$d_1$	L	$s_T$	$s_p$	Key
	1.	1.06	0.72	1.72	1.77	2.03	1217 (3/8 x 2 1/8)

### 4.15 Coupling dimensions

4.16	Keys for diameters	0,25 ~ 3,25	[in]
4.17	Min. shaft diameter	$d_{1min}$ 0,714	[in]
4.18	Shaft diameter	$d$ 1,063	[in]
4.19	Key	1217 (3/8 x 2 1/8)	<input checked="" type="checkbox"/>
4.20	Key width / height	$b / h$ 0,375   0,531	[in]
4.21	Key diameter / length	$D / L$ 2,125   1,723	[in]
4.22	Parameters of the key groove	$t / d_1$ 0,3385   0,724	[in]
4.23	Key chamfer	$e / s$ 0   0,01	[in]

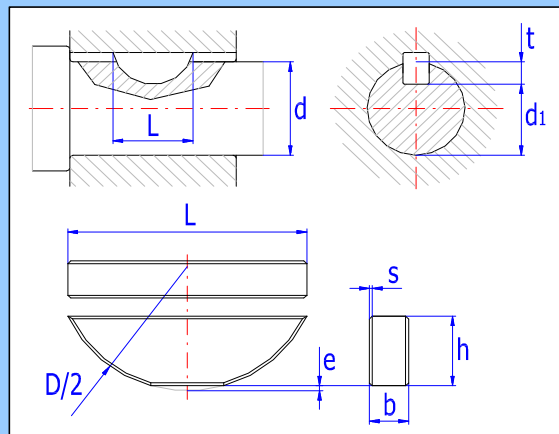

### 5.0 Strength checks of the coupling

5.1	Check of shaft for torsion	
5.2	Permitted stress in shear	$\tau_A$ 30 [ksi]
5.3	Comparative stress	$\tau$ 16,9 [ksi]
5.4	Safety	1,77

### 5.5 Check of shaft key groove for deformation

5.5	Check of shaft key groove for deformation	
5.6	Permissible pressure	$p_A$ 19 [ksi]
5.7	Comparative pressure	$p$ 9,4 [ksi]
5.8	Safety	2,03

5.9	<b>Check of key for deformation</b>			5.13	<b>Check of hub key groove for deformation</b>		
5.10	Permissible pressure	$p_A$	19 [ksi]	5.14	Permissible pressure	$p_A$	20 [ksi]
5.11	Comparative pressure	$p$	9,4 [ksi]	5.15	Comparative pressure	$p$	5,4 [ksi]
5.12	Safety		2,03	5.16	Safety		3,74

**C Straight-sided splines**

**6.0 Coupling parameters, dimensional design**

6.1	<b>Coupling parameters</b>		
6.2	Splines type	A ... SAE - Series A	
6.3	Load distribution factor	$K_L$	0,75
6.4	Total service factor	$K_S$	2,00
6.5	<b>Design of coupling dimensions</b>		
6.6	Splines for diameters	0,75 ~ 6 [in]	
6.7	Min. shaft diameter	$d_{min}$	0,714 [in]
6.8	Spline	1.000 - 1 x 4	
6.9	Spline outer diameter	$D$	1 [in]
6.10	Spline inner diameter	$d$	0,85 [in]
6.11	Number of grooves	$n$	4
6.12	Tooth width	$b$	0,241 [in]
6.13	Chamfer (radius)	$s$	0,005 [in]
6.14	Min. functional spline length	$L_{min}$	1,251 [in]
6.15	Chosen spline length	$L$	1,375 [in]

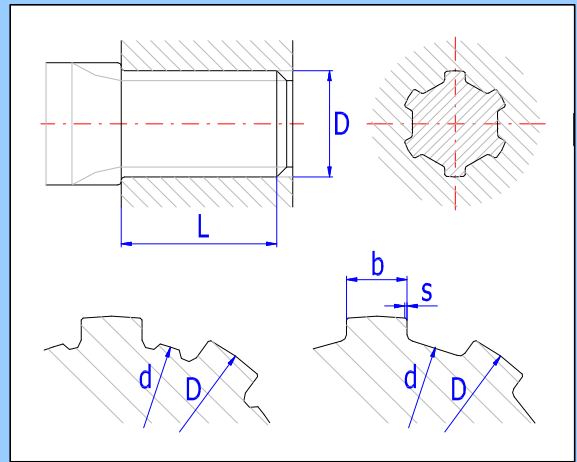

**7.0 Strength checks of the coupling**

7.1	<b>Check of shaft for torsion</b>			7.5	<b>Check of deformation of grooving sides</b>		
7.2	Permitted stress in shear	$\tau_A$	30 [ksi]	7.6	Permissible pressure	$p_A$	19 [ksi]
7.3	Comparative stress	$\tau$	10,5 [ksi]	7.7	Comparative pressure	$p$	10,2 [ksi]
7.4	Safety		2,87	7.8	Safety		1,87

**D Involute splines**

**8.0 Coupling parameters, dimensional design**

8.1	<b>Coupling parameters</b>		
8.2	Splines	C ... ANSI B92.1 - 30°, Fillet root, Side fit	
8.3	Load distribution factor	$K_L$	0,75
8.4	Total service factor	$K_S$	2,00
8.5	<b>Automatic design of the coupling</b>		
8.6	Filter for spline design	Complete series	
8.7	Assort design results according to	Outer diameter	
8.8	Hub maximum length	$L_{max}$	1,181 [in]
8.9	Start of design		
8.10	ID.	m/P	n
	1.	48.0	37
		0.79	0.73
		0.51	0.56
		1.81	1.89

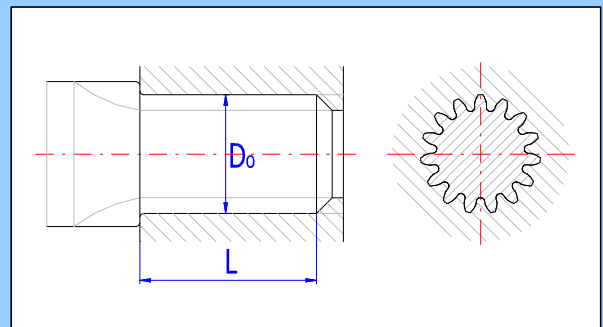

8.11	<b>Coupling dimensions</b>		
8.12	Min. shaft diameter	$D_{remin}$	0,714 [in]
8.13	Spline	0.792 - 48 x 37	
8.14	Pitch / Number of teeth	$P / n$	48 37 [1/in]
8.15	Pitch / base diameter	$D / D_b$	0,771 0,668 [in]
8.16	Reference diameter / shift	$D_d / x_m$	[in]
8.17	Diameters of external spline	$D_o / D_{re}$	0,792 0,729 [in]
8.18	Diameters of internal spline	$D_i / D_{ri}$	0,75 0,808 [in]
8.19	Tooth thickness / groove width	$t_v / s_v$	0,033 0,033 [in]
8.20	Circular pitch / form clearance	$p / c_f$	0,065 0,002 [in]
8.21	Min. functional spline length	$L_{min}$	0,507 [in]
8.22	Chosen spline length	$L$	0,563 [in]

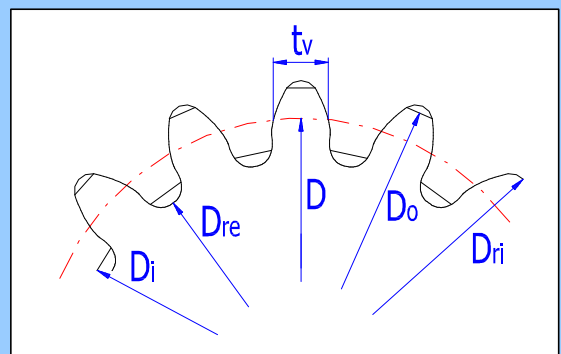

**9.0 Strength checks of the coupling**

9.1	<b>Check of shaft for torsion</b>			9.5	<b>Check of deformation of grooving sides</b>		
9.2	Permitted stress in shear	$\tau_A$	30 [ksi]	9.6	Permissible pressure	$p_A$	19 [ksi]
9.3	Comparative stress	$\tau$	16,6 [ksi]	9.7	Comparative pressure	$p$	10,1 [ksi]
9.4	Safety		1,81	9.8	Safety		1,89

**Additions section**

**10.0 Comparative table**

10.1 **Parallel side keys**

10.2 **5/16 x 5/16 ANSI B17.1**

10.3 Shaft diameter	d	1,375	[in]
10.4 Key length	L	1,75	[in]
10.5 Safety		1,97	

10.11 **Straight-sided splines**

10.12 **1 x 4 SAE - Series A**

10.13 Spline outer diameter	D	1	[in]
10.14 Spline inner diameter	d	0,85	[in]
10.15 Spline length	L	1,375	[in]
10.16 Safety		1,87	

10.6 **Woodruff's keys**

10.7 **1217 (3/8 x 2 1/8) ANSI B17.2 A**

10.8 Shaft diameter	d	1,063	[in]
10.9 Key length	L	1,723	[in]
10.10 Safety		1,77	

10.17 **Involute splines**

10.18 **48 x 37 ANSI B92.1 - 30°, Fillet root, Side fit**

10.19 Spline outer diameter	D <sub>o</sub>	0,792	[in]
10.20 Spline inner diameter	D <sub>re</sub>	0,729	[in]
10.21 Spline length	L	0,5626	[in]
10.22 Safety		1,81	

11.0  **Graphical output, CAD systems**

- 11.1 2D drawing output to: DXF File ▼
- 11.2 2D Drawing scale: Automatic ▼

